

PILATUS

Maschinenbau AG

- Created and manufactured the first Roller-Turning Machine in the 1970's
 - The Roller-Turning Machines:
 - Can be combined with roller mills of all makes and are available for all roller widths even where mounting space is limited
 - Shortens the breakdown time in the preparation process
 - Allows for a 20% to 40% faster cutting speed
 - The electronic drive sets new standards in contact precision and in process continuity
 - The service life of the PILATUS Roller-Turning Machines is almost unlimited
 - All safety precautions comply with the CE Standard Specifications



PILATUS

Maschinenbau AG

- Two different turning systems have been developed to maintain an optimal roller equality of the rough and fine roller mills:

The Single-Point System for rough roller mills



The TWIN System, which is more precise and faster, for the fine roller mills



SINGLE-POINT SYSTEM

- Works with one cutting tool
- The service life of the PILATUS roller turning machines is almost unlimited



WDM/P with a Low Bed



WDM with a High Bed



THE TWIN SYSTEM

- Works with two cutting tools simultaneously
- The roll machining time is almost reduced by half



The WDM/P with a Low Bed



The WDM/TWIN with a High Bed



SPECIAL BASE

- This is the most important requirement for a precise and ideal roller gap

The PILATUS machine bed

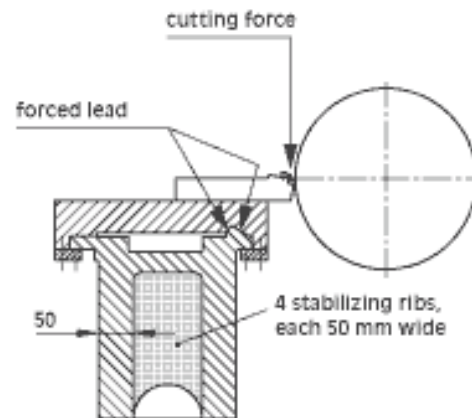

Only PILATUS' specially designed roller turning machine bench has the capacity to indefinitely contend with the high-stress demands of roller-mill operation.

The conventional machine bed

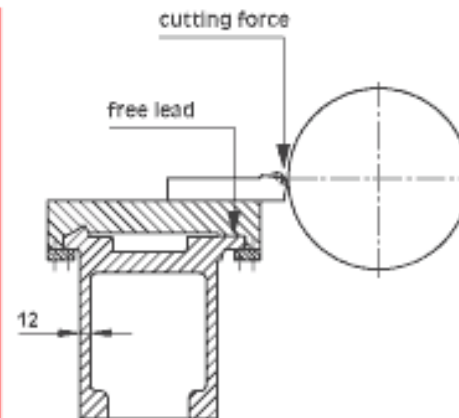

Conventional proprietary roller turning machine benches are faulty to the point of allowing major deviations.



ANTI-VIBRATION SYSTEM

- This system protects the Roller-Turning Machines from the enormous shaking and impact during the grinding process
- Precision remains constant and the Roller-Turning Machine's service life is considerably prolonged
- This system is integrated into the base of the Roller-Turning Machine

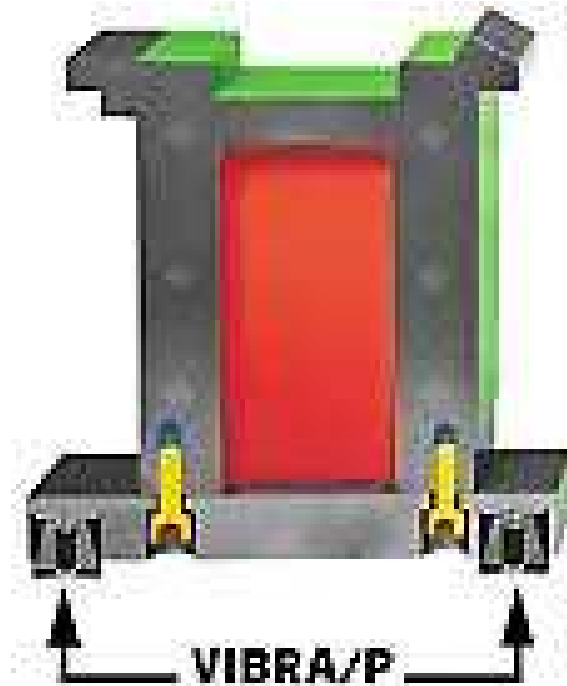

Integrated anti-vibration protection



REVISIONING SYSTEMS

- The solid construction and the high quality values of the PILATUS Roller-Turning Machines justify the expense of an occasional revision.

